



January, 2025

Dear Potential Bidder:

The Champaign Park District is requesting bids to replace the existing asphalt shingle systems with new metal roofing on three (3) separate concession and restroom buildings located within Dodds Park, 1501 N. Mattis Ave., Champaign, IL.

General scope of work includes: all necessary labor, materials, and equipment to remove the existing shingles, replace any sheathing as needed, and install a new metal roofing system.

Enclosed is a copy of the bid information.

Sealed bids shall be delivered or mailed to Bret Johnson, Champaign Park District, 706 Kenwood Road, Champaign, Illinois 61821 **by 1:30 p.m. prevailing time on Thursday, January 30, 2025.**

Sealed bid packets shall be clearly marked with the words: **"Bid Document: DODDS PARK ROOFING"**, along with the bidder's name and address, on the outside of the envelope.

When submitting your sealed bid, please make sure to enclose the following:

1. Bid Sheet
2. Commitment to Engage in Affirmative Action Practices
3. Affirmative Action Contractor's Compliance Report

If you have any questions regarding the project, or any of the enclosed information please contact me at 217-819-3850, 7:30 a.m. to 4:00 p.m., weekdays, or bret.johnson@champaignparks.org

Sincerely,

Bret Johnson
Assistant Director of Operations & Planning

Enc.

Champaign Park District
706 Kenwood Road
Champaign, Illinois 61821-4112
217.398.2550 Phone
217.355.8421 Fax
www.champaignparks.org

Park Commissioners
Craig W. Hays
Barbara J. Kuhl
Timothy P. McMahon
Jane L. Solon
Michael R. Somers

Officers
Jarrod Scheunemann, *Secretary*
Guy C. Hall, *Attorney*
Donna K. Lawson, *Treasurer*
Sarah Sandquist, *Executive Director*

Champaign Park District: Invitation for Bids – Dodds Park Roof Replacements

SECTION I. INSTRUCTIONS TO BIDDERS

- 1.01 Invitation to Bid: The Champaign Park District is soliciting bids from contractors to furnish all labor, material, supplies, equipment, and supervision to fully replace the existing asphalt shingle roofing systems with new standing seam metal roofing on three (3) separate concession and restroom buildings located within Dodds Park, as outlined in the specifications.

Bid documents can be obtained online at: <https://champaignparks.com/bids-rfps/> or by contacting Bret Johnson, Champaign Park District, 706 Kenwood Road, Champaign, Illinois 61821 @ 217.819.3850

- 1.02 Due Date: Sealed bids shall be delivered or mailed to **Champaign Park District, 706 Kenwood Road, Champaign, Illinois 61821, by 1:30 p.m.** prevailing time on **Thursday, January 30, 2025**, at which time bids will be opened and publicly read. Facsimile copies and late bids will not be accepted.

- 1.03 Bid Understanding: By submitting a bid, the bidder agrees and assures that the specifications are adequate, and the bidder accepts the terms and conditions, specifications and requirements of work to be completed. Failure to do so will be at the bidder's risk and they cannot secure relief on the plea of error.

- 1.04 Submission of Bid: All bids shall be submitted on the **Bidder's Response Forms** and accompanied by requested information including the **Champaign Park District Commitment to Engage in Affirmative Action Practices forms**. All blank spaces shall be properly filled in, in ink or typewritten, in both words and figures, and with no other conditions, changes, erasures or interlineations. Bids shall be signed and executed by a principal duly authorized to make contracts.

Bids shall be enclosed in an envelope sealed and clearly marked with the words: "**BID DOCUMENT: ROOF REPLACEMENTS**" The bidder shall put their name and address on the outside of the envelope.

The Champaign Park District shall not be responsible for the premature opening of bid envelopes, which are not properly filled out in accordance with the instructions.

- 1.05 Site Visits: It shall be the sole responsibility of the bidder to inspect the location(s) prior to submitting a bid. No variation in price or conditions shall be permitted based upon a claim of ignorance. Submission of a bid shall be considered evidence that the bidder has familiarized himself/herself with the nature and extent of the work, and the equipment, materials and labor required.

- 1.06 Awards Criteria: Award will be to the lowest priced, responsible bidder if all other requirements are satisfactorily met. The Champaign Park District reserves the right to reject any and all bids, waive technicalities and irregularities and/or to award the contract only to a bidder who is equipped, competent and experienced in the class of work and whose bid is deemed to be advantageous to the interests of the Champaign Park District.

- 1.07 Rejection of Bids: The Park District reserves the right to reject any, all, or any part of a bid, and waive any or all irregularities and select the bid that is in its best interest. The Park District reserves the right to reject the bid of any bidder who previously failed to perform adequately for the Park District or any other governmental agency or company.

- 1.08 Withdrawal: Bidder may make a written request to modify or withdraw the offer at any time prior to the opening. Bids may not be modified after submittal or withdrawn or modified after bid opening. Withdrawal of bids will be allowed if award of contract has been delayed more than 60 days, after date of actual bid opening.

- 1.09 Inquiries: Questions and comments regarding this solicitation should be directed to the **Bret Johnson, Assistant Director of Operations & Planning**, at Bresnan Meeting Center, 706
-

Champaign Park District: Invitations for Bids – Dodds Park Roof Replacements

Kenwood Road, Champaign, Illinois 61821 or by calling **217-819-3850**. Written answers to questions of a general nature or which would affect the solicitation will be provided to all eligible bidders. Only written answers to the questions shall be binding.

SECTION II. TERMS AND CONDITIONS

- 2.01 Definitions: *Owner* shall mean the Champaign Park District. *Contractor* shall mean party of the second part to this contract, acting directly or through his or its legal representative(s) or agent(s). *Subcontractor* shall mean persons, firms or corporations having a direct contract with the contractor, and those who contract to furnish labor or labor and materials at the site of the project.
- 2.02 Contract Documents: The contract entered into by the parties shall consist of the Instructions to Bidder, Terms and Conditions, Specifications, and Bid Forms including all modifications thereof, and a purchase order, if applicable, requiring signatures of the Champaign Park District and the Contractor, all of which shall be referred to collectively as the Contract Documents.
- 2.03 Payments: Contractor shall submit invoice to the District by the 1st Friday of the month. Late submissions will be pushed to the next month's billing by the Park District. Payment will be monthly after Board approval of the bills, which is the 2nd Wednesday of each month.
- 2.04 Taxes: The District is exempt from any taxes imposed by State and/or Federal Government. Exemption certificates will be provided upon request.
- 2.05 Cancellation/Termination: The Park District may cancel this contract for convenience by providing thirty (30) calendar days advance notice to the contractor.
- The Park District may cancel this contract for cause (i.e., fails to meet deadlines, fails to provide agreed upon service, etc.) at any time by giving one week's written notice to the contractor. The termination of the contract will be issued only after the District deems that the contractor has failed to remedy the problem after being forewarned.
- The Contractor may cancel this contract for convenience or cause by providing thirty (30) calendar days advance notice to the District.
- 2.06 Compliance or Deviation to Specifications: Bidder hereby agrees that the equipment or services offered will meet all the requirements of the specifications in this solicitation unless deviations from them are clearly indicated in the Bidder's response. Bidder may submit an attachment entitled "Exceptions for Specification", which must be signed by Bidder's authorized representative. An explanation must be made for each item to which an exception is taken, giving in detail the extent of the exception and the reason for which it is taken. Bids failing to comply with this requirement will be considered non-responsive.
- 2.07 Compliance with Ordinances and Statutes and Notice of Special Conditions: Every bidder shall comply with the requirements of the Affirmative Action Regulations of the Champaign Park District, Illinois Fair Employment Act, Illinois Prevailing Wage Act, Equal Opportunity regulations and other Federal and State of Illinois regulations and guidelines applicable to the contract.
- 2.08 Assignment and Subcontracts: The Contractor shall not assign this contract or any part thereof without written consent of the Park District, nor shall the Contractor award any work under this contract to any subcontractor without prior written approval from the Director of Operations or the Executive Director. Nothing contained in the contract documents shall create a contractual relation between any subcontractor and the Owner. Any subcontractor assigned must meet the same requirements as the Contractor awarded the bid.
- 2.09 Independent Contractor: The contractor acknowledges and agrees that the Contractor is not an employee of the Park District, is not entitled to any benefits or protections afforded employees of the Park District, nor bound by any obligations of employees of the Park District. Nevertheless, the

Champaign Park District: Invitation for Bids – Dodds Park Roof Replacements

Contractor will not act contrary to the policies of the Park District. The Contractor understands and fully agrees that the Contractor will not be insured under provisions of the unemployment compensation insurance of the Park District or the workers' compensation insurance of the Park District, and that any injury or property damage in connection with the work performed will be the Contractor's sole responsibility and not that of the Park District. It is also understood that the Contractor is not protected as an employee or as a person acting as an agent or employee under the provisions of the general liability insurance of the Park District and, therefore, the Contractor will be solely responsible for the Contractor's own acts or omissions, and those of the Contractor's employees and agents, if any. The Park District will not in any manner whatsoever be obligated to defend, indemnify or hold harmless the Contractor, or the Contractor's employees and agents, if any, in matters of liability.

- 2.10 Indemnification: Contractor shall indemnify and hold harmless District and its officers, officials, employees, volunteers and agents from and against all claims, damages, losses and expenses, including but not limited to legal fees (attorneys' and paralegals' fees and court costs) arising out of or resulting from the performance of Contractor's work, provided that any such claim, damage, loss or expense (i) is attributable to bodily injury, sickness, disease or death, or injury to or destruction of tangible property, including the loss of use therefrom, and (ii) is caused in whole or in part by any wrongful or negligent act or omission of Contractor, any Subcontractor, anyone directly or indirectly employed by any of them or anyone for whose acts any of them may be liable, except to the extent it is caused in part by a party indemnified hereunder. Such obligation shall not be construed to negate, abridge, or otherwise reduce any other right or obligation of indemnification which would otherwise exist as to any party or person described in this Paragraph. Contractor shall similarly protect, indemnify and hold and save harmless District, its officers, officials, employees, volunteers and agents against and from any and all claims, costs, causes, actions and expenses including but not limited to legal fees, incurred by reason of Contractor's breach of any of its obligations under, or Contractor's default of, any provision of the Agreement.
- 2.11 Insurance: The Contractor shall purchase and maintain such insurance as will protect him/her from claims under worker's compensation acts and from claims or damages because of bodily injury, including death, and all property damage, including without limitation, which might arise during operations under this contract, whether such operations be by himself/herself or by any subcontractor or anyone directly or indirectly employed by either of them. After award of bids by the Park Board of Commissioners, Contractor shall provide a Certificate of Insurance. Failure to do so will result in loss of the contract, which will be awarded to the next lowest responsible bidder. Contractor shall maintain minimum limits of insurance no less than:
- (a) Workman's Compensation as required by statute and Employers Liability Insurance: Employers Liability limits shall not be less than \$1,000,000 each accident for bodily injury by accident or \$1,000,000 each employee for bodily injury by disease.
 - (b) General Liability: a limit of not less than \$1,000,000 each occurrence
 - (c) Automobile Liability: limit of not less than \$500,000 each accident

Failure to maintain the required insurance may result in termination of this Contract.

- 2.12 Bid Security: Each bid must be accompanied by a certified cashier's check, certified check, or a bid bond duly executed by the bidder as principal and having as surety thereon a surety company approved by the Owner, in the amount of 10% of the total bid. Such cash, checks, or bid bonds will be returned to all except the three lowest bidders within three (3) days after the opening of bids, and the remaining cash, checks, or bid bonds will be returned promptly after the Owner and the accepted bidder have executed the contract, or, if no award has been made within thirty (30) days after the date for the opening of bids, upon demand of the bidder at any time thereafter, so long as he has not been notified of the acceptance of his/her bid.
- 2.13 Performance Bond: Within ten (10) days after the award of contract, the successful Contractor shall furnish a Performance Bond in the amount of 100% of the contract and the payment of all obligations arising thereunder, using a form similar to the A.I.A. - 311 Form or one acceptable to the Owner. The
-

Champaign Park District: Invitations for Bids – Dodds Park Roof Replacements

Performance Bond will become part of the contract. The failure of the successful bidder to enter into contract and supply the required bonds within ten (10) days after the prescribed forms are presented for signature, or within such extended period as the Owner may grant, shall constitute a default and the Owner may either award the contract to the next responsible bidder or re-bid the project. A charge against the defaulting bidder may be made for the difference between the amount of the bid and the amount for which a contract for the work is subsequently executed, irrespective of whether the amount thus due exceeds the amount of the bid guarantee.

- 2.14 Liquidated Damages for Failure to Enter into Contract: The successful bidder, upon his/her failure to execute and deliver the contract and bond required within ten (10) days after he/she has received notice for the acceptance of his/her bid, shall forfeit to the Owner, as liquidated damages for such failure or refusal, the security deposited with his/her bid and in addition thereto, shall be liable for such damages as the Other may sustain by reason of such refusal.
- 2.15 Time of Completion and Liquidation Damages: Bidder shall agree to commence within fifteen (15) days after award of contract and to **fully complete the project by April 30, 2025** unless prevented by adverse weather, or schedule conflict with District programming.
- 2.16 Bid Rigging or Bid Rotating: The bidder by affixing his or her signature to the bid, certifies that he/she has not been barred from being awarded a contract with a unit of State or local government as a result of a violation of Section 33E-3 or 33E-4 of the Criminal Code of 1961.
- 2.17 Sexual Harassment Policy: Contractor certifies that it has a written sexual harassment policy that includes the following information:
- The illegality of sexual harassment.
 - The definition of sexual harassment under State Law.
 - A description of sexual harassment utilizing examples.
 - The Contractor's internal complaint process including penalties.
 - The legal recourse, investigative and complaint process available through the Illinois Department of Human Rights and Equal Employment Opportunity Commission.
 - Protection against retaliation against a person because he or she has opposed that which he or she reasonably and in good faith believes to be sexual harassment or because he or she has made a charge, filed a complaint, testified, assisted, or participated in an investigation, proceedings or hearing under the Illinois Human Rights Act or any other civil rights statute.
- A copy of the policies shall be provided to the District upon request.
- 2.18 Protest: If bidder objects to any provision of the bid, believes the District improperly rejected your offer, or believes the selected offer is not in the Champaign Park District's best interests, bidder may submit a written protest to the Executive Director within five (5) days after the opening. Owner will consider only written protests that are properly and timely filed with the District. Owner will issue a written decision and that decision is final.
- 2.19 Existing Hazardous Materials: It will be the contractor's responsibility to take all necessary steps to remove the materials and to protect all persons involved with the project and all persons in the building and in the vicinity of the site from asbestos. Further, the contractor assumes all liability from asbestos exposure and removals and shall hold the Owner(s), Consultant(s), and Manufacturer(s) harmless.
- Asbestos removal shall be governed by all regulatory agencies. This includes but is not necessarily limited to EPA, OSHA, NIOSH, NESHAP, and any other applicable codes and regulations. Contractor shall submit all copies of current guidelines. The Contractor shall remove known ACBM's in accordance with all regulations.
 - Asbestos found in flashings only shall be left in place. New flashings will be applied to existing and/or to encapsulate same.
- 2.20 OSHA Standards: All current OSHA Standards, as of now the and through the project, shall be strictly adhered to. Contractor is responsible for acquiring copies of new regulations and submitting them to the Owner, upon request.

Champaign Park District: Invitation for Bids – Dodds Park Roof Replacements

SECTION III. SPECIFICATIONS

3.1 Locations & Descriptions

- A. Dodds Park Soccer Complex: 1501 N. Mattis Ave., Champaign, IL
- Remove and dispose of all existing roofing materials including all shingles, underlayment, flashing, and drip edge. Existing gutters and downspouts to be reused.
- Repair/replace any damage sheathing plywood, fascia boards, and/or venting apparatuses.
- Replace with McElroy metal standing seam roofing system. Roughly 4,223 sqft.
- B. Dodds Park 4-Plex Softball: 1501 N. Mattis Ave., Champaign, IL
- Remove and dispose of all existing roofing materials including all shingles, underlayment, flashing, and drip edge. Existing gutters and downspouts to be reused.
- Repair/replace any damage sheathing plywood, fascia boards, and/or venting apparatuses.
- Replace with McElroy metal standing seam roofing system. Roughly 5,161 sqft
- C. Dodds Park 3-Plex Softball: 1501 N. Mattis Ave., Champaign, IL
- Remove and dispose of all existing roofing materials including all shingles, underlayment, flashing, and drip edge. Existing gutters and downspouts to be reused.
- Repair/replace any damage sheathing plywood, fascia boards, and/or venting apparatuses.
- Replace with McElroy metal standing seam roofing system. Roughly 863 sqft

3.2 Products

- A. Manufacturer: McElroy Metal, Inc.
- Contact: 1500 Hamilton Rd., Bossier City, LA 71111; Telephone: (800) 950-6531; Fax: (318) 747-8099; E-mail: info@mcelroymetal.com; website: www.mcelroymetal.com.
 - Products: McElroy Metal Preformed Sheet Metal Roofing Panels.
- B. Substitutions:
- Substitution Limitations
 - Requests for approval must be submitted in writing at least ten (10) days prior to bid date and are accompanied by all related test reports and design calculations.
 - Substitute manufacturers will be approved by written addendum to all bidders. Voluntary alternates will not be considered. Substitutions will not be permitted after the bid date of this project.
 - Roof panels proposed for substitution shall fully match the specified requirements in appearance, assembly, and performance.
- C. McElroy Metal Medallion-Lok Panels
- Profile: Vertical leg standing seam panel with male/female seams that are interlocked via snapping during installation.
 - Size: 1.75" high seam by 16" width
 - Panel Surface: Bead (Pencil Rib) Profile
 - Material: Galvalume steel sheet conforming to ASTM A792, AZ55 coating for bare; AZ50 coating for painted; [24 standard; 22 Optional-minimum quantities may apply] gauge sheet thickness.
 - Color: TBD from standard manufacturer options.
-

Champaign Park District: Invitations for Bids – Dodds Park Roof Replacements

3.3 Metal Roof Panel Accessories

- A. General: Provide complete metal roof panel assembly incorporating trim, copings, fasciae, and miscellaneous flashings. Provide required fasteners, closure strips, support plates, and sealants as indicated in manufacturer's written instructions.
- B. Flashing and Trim: Match material, thickness, and finish of metal panel face sheet.
- C. Panel Clips: ASTM A 653/A 653M, G90 (Z180) hot-dip galvanized zinc coating, configured for concealment in panel joints, and identical to clips utilized in tests demonstrating compliance with performance requirements.
- D. Panel Fasteners: Self-tapping screws and other acceptable corrosion-resistant fasteners recommended by the panel manufacturer. Where exposed fasteners cannot be avoided, supply fasteners with EPDM or neoprene gaskets, with heads matching color of metal panels by means of factory-applied coating.
- E. Joint Sealers: Manufacturer's standard or recommended liquid and preformed sealers and tapes, and as follows:
 - 1. Factory-Applied Seam Sealant: Manufacturer's standard hot-melt type.
 - 2. Tape Sealers: Manufacturer's standard non-curing butyl tape, AAMA 809.2.
 - 3. Concealed Joint Sealant: Non-curing butyl, AAMA 809.2.
- F. Steel Sheet Miscellaneous Framing Components: ASTM C 645, with ASTM A 653/A 653M, G60 (Z180) hot-dip galvanized zinc coating.
- G. Misc. Roof Accessories: Approved by metal roof panel manufacturer.
- H. Snow Guards: Approved by metal roof panel manufacturer.

3.4 Installation

- A. General: Install metal roofing panels to profiles, patterns and drainage indicated and required for leak-proof installation. Provide for structural and thermal movement of work. Seal joints for leak-proof installation.
 - 1. Shim or otherwise plumb substrates receiving metal panels.
 - 2. Flash and seal metal panels at perimeter of all openings. Fasten with self-tapping screws.
 - 3. Do not begin installation until air- or water-resistive barriers and flashings that will be concealed by metal panels are installed.
 - 4. Install screw fasteners in predrilled holes for clip installation.
 - 5. Locate and space fasteners in uniform vertical and horizontal alignment.
 - 6. Install flashing and trim as metal panel work proceeds.
 - 7. Install continuous length panels.
 - 8. Align bottoms of metal panels and fasten with blind rivets, bolts, or self-tapping screws.
 - 9. Fasten flashings and trim around openings and similar elements with self-tapping screws.
 - 10. Provide weathertight EPDM Flashing for pipe- and conduit-penetrating panels.
 - 11. Seams: Provide uniform, neat seams.
 - 12. Fix panels at location depicted on reviewed shop drawings.
 - 13. Allow for required panel clearance at penetrations for thermal movement.
 - 14. Align pipe penetrations to occur at center of roof panel. Report and have corrected improperly placed penetrations before proceeding with panel installation. Remove and replace roof panels which have improperly placed penetration flashings.

Champaign Park District: Invitation for Bids – Dodds Park Roof Replacements

15. Allow for required panel clearance at penetrations for thermal movement.
 16. Fasteners: Conceal fasteners where possible in exposed work. Cover and seal fasteners and anchors for watertight and leak-proof installation.
 17. Sealant-Type Joints: Provide sealant-type joint where indicated. Form joints to conceal sealant. Comply with Division 7 Joint Sealants Section for sealant installation.
- B. Roofing Installation:
1. Install roofing plumb, true and in correct alignment with structural framing, in accordance with shop drawings and manufacturer's printed installation instructions.
 2. Install roofing using manufacturer's concealed fastening system or non-corroding fasteners color-matched to panel.
 3. Install trim using concealed fasteners where possible; sight-exposed non-corroding fasteners color-matched to trim are permitted on vertical surfaces only.
- C. Installation Tolerances:
1. Variation from Plumb: Maximum 1/8" (3.2 mm) in 20 feet (6.096 m).
 2. Variation from Level: Maximum 1/8" (3.2 mm) in 20 feet (6.096 m).
 3. Variation from True Plane: Maximum 1/4" (3.2 mm) in 20 feet (6.096 m).
- D. Underlayment Installation:
1. Underlayment to be supplied by metal roof panel manufacturer.
 2. Self-adhered High-Temperature Underlayment: Provide self-adhering, cold-applied, sheet underlayment, a minimum of 40 mils thick adhesive, with release-paper backing. Provide primer when recommended by underlayment manufacturer.
 3. Thermal Stability: Stable after testing at 240 degree F; ASTM D1970.
 4. Low-Temperature Flexibility: Passes after testing at minus 20 degree F; ASTM D1970.
- E. Accessory Installation: Install accessories using techniques recommended by manufacturer and which will assure positive anchorage to building and weathertight mounting. Provide for thermal movement. Coordinate installation with flashings and other components
- F. Flashing and Trim Installation: Comply with performance requirements, manufacturer's written installation instructions, and the SMACNA "Architectural Sheet Metal Manual." Provide concealed fasteners where possible, and install units to true level. Install work with laps, joints, and seams that will be permanently watertight.
- G. Metal Roof Curbs: .063 minimum thickness welded aluminum, or 18 gauge minimum welded stainless steel, factory-insulated, with integral cricket, and designed to fit roof panel module, sized to meet specification.

3.5 Cleaning

- A. Cleaning: Remove temporary coverings and protection of adjacent work areas.
 - B. Repair or replace damaged installed products.
 - C. Clean installed products in accordance with manufacturer's instructions prior to Owner's acceptance.
 - D. Remove construction debris from project site and legally dispose of debris.
-

Champaign Park District: Invitations for Bids – Dodds Park Roof Replacements

3.6 Protection

- A. Protection: Protect installed product's finish surfaces from damage during construction:
 - 1. Protect installed products from damage by subsequent construction activities.
 - 2. Replace products having damage other than minor finish damage.
 - 3. Repair products having minor damage to finish in accordance with panel Manufacturer's recommendation
 - 4. Owner shall be sole judge of acceptability of repair to damaged finishes; replace products having rejected repairs.

3.7 Warranty

- A. Product Warranty:
 - 1. Panel Material: Furnish manufacturers 45 year warranty covering the panel against rupture, structural failure, or perforation.
 - 2. Panel Coating: Furnish manufacturer's 40-year warranty covering cracking, checking, and peeling, and 30 year warranty covering fade and chalk on the Two coat coil applied, baked on full strength (70% resin, PVF2) fluorocarbon coating.
- B. Special Warranty: Installer's standard form in which installer agrees to repair or replace panels that fail due to poor workmanship or faulty installation within the specified warranty period.

3.8 Project Conditions

- A. Field Measurements: Verify actual measurements/openings by field measurements before fabrication; show recorded measurements on shop drawings.
- B. Weather Limitations: Proceed with installation only when existing and forecasted weather conditions permit assembly of metal panels to be performed in accordance with manufacturers' written instructions and warranty requirements.

3.9 Quality Assurance

- A. Manufacturer Qualifications:
 - 1. Provider of "hands on" installer training at manufacturer or customer facility.
 - 2. Minimum of ten years' experience in manufacturing metal roof systems.
 - 3. Provider of product produced in a permanent factory environment with fixed roll-forming equipment and also possesses the capability to roll form continuous panels on jobsites with a factory technician for jobs with panel lengths in excess of 50'
- B. Installer Qualifications:
 - 1. At least five years' experience in the installation of structural standing seam metal roof panels.
 - 2. Experience on at least five projects of similar size, type and complexity as this project that have been in service for a minimum of two years with satisfactory performance of the roof system.
 - 3. Employer of workers for this project who are competent in techniques required by manufacturer for installation indicated and who shall be supervised at all times when material is being installed.

Champaign Park District: Invitation for Bids – Dodds Park Roof Replacements

3.10 Administrative Requirements

- A. Pre-installation:
 - 1. **Contractor must obtain a roofing permit for each site, through the City of Champaign. All costs shall be covered by the contractor.**
 - 2. Schedule meeting to discuss project requirements, substrate conditions, manufacturer's installation instructions and manufacturer's warranty requirements before start of work onsite.

Champaign Park District: Invitations for Bids – Dodds Park Roof Replacements

BIDDER'S RESPONSE FORM

Bidder shall provide all labor, materials, and equipment in accordance with the specifications listed previously regarding the shingle roof replacements at the Operations Facility and Prairie Farm. The bidder States that he/she has visited the site and familiarized their self with the conditions that affect cost of work.

BID AMOUNT: Dodds Soccer Complex

\$ _____

BID AMOUNT: Dodds 4-plex Softball

\$ _____

BID AMOUNT: Dodds 3-plex Softball

\$ _____

TOTAL BID AMOUNT (all 3 combined):

\$ _____

UNIT COSTS

PLYWOOD DECKING _____
(Per sq.ft. \$ amount for plywood deck replacement)

FASCIA BOARDS _____
(Per linear foot of 1"x6")

(Per linear foot of 1"x8")

Champaign Park District: Invitation for Bids – Dodds Park Roof Replacements

Insurance Statement: By signing the bid documents, bidder hereby certifies that the bidder had reviewed and understands the insurance coverage requirements specified in the Bid specification. Should the bidder be awarded the contract for work, bidder further certifies that the bidder can meet the specified requirements, agrees to name the Park District as an additional insured for the work specified, and submit the Certificates of Insurance providing coverage as specified within ten (10) calendar days of award of contract.

Bid Security: By signing the bid documents, bidder hereby certifies that the bidder has reviewed the bid security, Liquidated Damages for Failure to Enter into Contract, Time of Completion and Liquidated Damages, Security of Faithful Performance and Power-of-Attorney provisions and understands the requirements in the specifications and agrees to meet the specified requirements.

I hereby certify that I am duly authorized to sign as a representative for the contractor submitting the attached bid to the Champaign Park District, and that they have read, fully understand, and accept the items detailed in this bid.

Signed this _____ day of _____, 20__.

SUBMITTED BY:

Company

Address

Phone

Fax

Email Address

Authorized Agent (print or type)

Signature of Authorized Agent

FIN or SS #

Addendum Acknowledgement

Bidder hereby acknowledges receipt of the following Addenda:

001 _____
Date

002 _____
Date

003 _____
Date

Champaign Park District: Invitations for Bids – Dodds Park Roof Replacements

SECTION V: COMMITMENT TO ENGAGE IN AFFIRMATIVE ACTION PRACTICES

A. The undersigned bidder/contractor/supplier/vendor understands and agrees:

It is the policy of _____ *(name of company)* that all applicants for employment and all employees be recruited, hired and assigned on the basis of merit without discrimination because of race, creed, color, national origin, sex, age or disability. The employment practices of this company have been and will continue to be such as to insure that all employees are treated equally and that no distinctions are made in rates of pay, benefits or opportunities for advancement.

Therefore employment of individuals, their assignment to jobs, their transfers and their promotions shall be determined by matching the requirements of an open position with the candidate's skills and qualifications without regard to race, creed, color, national origin, sex, age or disability.

All management and supervisory personnel shall continue to take positive action to insure that all principles and objectives of the affirmative action program are complied with to carry out the provisions of the laws governing non-discrimination in employment.

- B. The undersigned bidder/contractor/supplier/vendor understands and agrees: to submit to the park district upon request written evidence of the effectiveness of the above-required practices, policies and goals.
- C. The undersigned bidder/contractor/supplier/vendor understands and agrees: to submit to the park district upon request statistical data concerning employee composition or membership composition by race, color, sex, age, disability and job description.
- D. The undersigned bidder/contractor/supplier/vendor understands and agrees: to distribute copies of the above commitment (A) to all persons who participate in recruitment, screening, referral and selection of job applicants and prospective job applicants or members.
- E. The undersigned bidder/contractor/supplier/vendor understands and agrees: to require any subcontractor to submit to the District a written commitment with who he/she contracts with in the amount of \$5,000.00/Sub-Contract or \$1,000.00/Supplier/Vendor (per purchase or in accumulated amount in any fiscal year of the District) or more to engage in Affirmative Action practices.

I certify that I have answered all the foregoing questions and provided all the foregoing information correctly and truthfully to the best of my knowledge and ability.

Signature of Authorized Agent

Date

Title

Telephone Number

All information provided the Champaign Park District will be held in strictest confidence.

Champaign Park District: Invitation for Bids – Dodds Park Roof Replacements

SECTION VI: AFFIRMATIVE ACTION CONTRACTOR'S COMPLIANCE REPORT

Part I: Identification

1. Company's main office address: _____

Telephone: _____ Fax: _____

Federal employer's identification number: _____

2. In what capacity would the company do business with the Park District?
 Contractor Sub-contractor Vendor Supplier Other _____

3. Major activity of company (principle product or service). _____

4. Is the company presently pre-qualified to do business with the Park District or other local and/or state government?
 Yes No *If yes with what agency(ies)?* _____

During the last 12 months has the company performed business with any governmental agency federal, state, county, municipal, school districts, etc.)?
 Yes No *If yes with what agency(ies)?* _____

Part II: Policies and Practices

A. Is the company's policy to recruit, hire, train, upgrade, promote and discipline persons without regard to race, color, religion, sex, national origin or ancestry, age or disability? Yes No

B. Has the company developed a written affirmative action policy?
 Yes No *If yes, a copy of the policy shall be provided to the District upon request.*

C. Does the company have an affirmative action officer or person responsible for affirmative action?
 Yes *If yes please complete.* No

Name: _____

Title: _____

Telephone: _____

C. Does the company have bargaining agreements with employee organizations?
 Yes No

If yes, have such organizations been notified of the company's responsibility to comply with the Champaign Park District's affirmative action program? Yes No

Comments: _____

Champaign Park District: Invitations for Bids – Dodds Park Roof Replacements

SECTION VI: AFFIRMATIVE ACTION CONTRACTOR'S COMPLIANCE REPORT (CONTINUED)

E. Has the company notified all of its sub-contractors of their obligations to comply with the Champaign Park District's affirmative action program? Yes No

Comments: _____

Part III: Personnel Inventory

Occupations	White		Black		Hispanic		Other	
	Male	Female	Male	Female	Male	Female	Male	Female
Officials & Managers								
Professionals								
Technical								
Sales Workers								
Office & Clerical								
Crafts (skilled)								
Operatives (semi-skilled)								
Laborers (unskilled)								
Service Workers								
Apprentices (blue collar)								
On the job trainees (blue collar)								
On the job trainees (white collar)								
Totals								

The undersigned bidder/contractor/vendor/supplier has analyzed the workforce and submits the following workforce figures. The Champaign Park District will hold all information in the strictest confidence.

Above employee figures were obtained from: Visual check Employment records

 Signature of Authorized Agent

 Date

 Title

 Telephone Number

Dodds Park Soccer Complex- 1501 N. Mattis Ave.

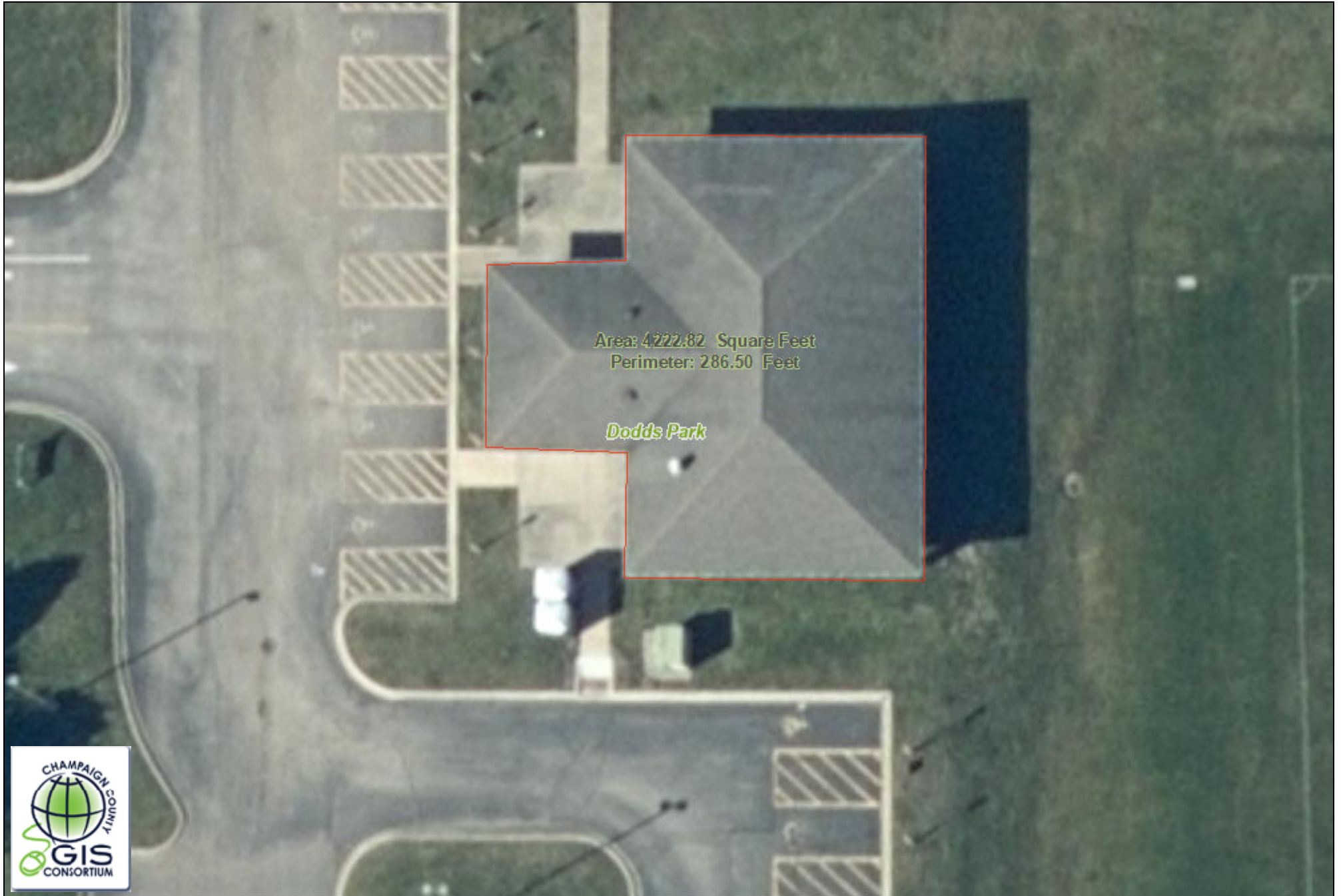

Dodds Park 4-Plex Softball Complex- 1501 N. Mattis Ave.



25

Feet

This map was prepared with geographic information system (GIS) data created by the Champaign County GIS Consortium (CCGISC), or other CCGISC member agency. These entities do not warrant or guarantee the accuracy or suitability of GIS data for any purpose. The GIS data within this map is intended to be used as a general index to spatial information and not intended for detailed, site-specific analysis or resolution of legal matters. Users assume all risk arising from the use or misuse of this map and information contained herein. The use of this map constitutes acknowledgement of this disclaimer.



Dodds Park 3-Plex Softball Complex- 1501 N. Mattis Ave.



10

Feet

This map was prepared with geographic information system (GIS) data created by the Champaign County GIS Consortium (CCGISC), or other CCGISC member agency. These entities do not warrant or guarantee the accuracy or suitability of GIS data for any purpose. The GIS data within this map is intended to be used as a general index to spatial information and not intended for detailed, site-specific analysis or resolution of legal matters. Users assume all risk arising from the use or misuse of this map and information contained herein. The use of this map constitutes acknowledgement of this disclaimer.



Installation is a snap

Medallion-Lok is a snap-together architectural panel with structural capabilities that features a rigid 1.75" standing seam. Medallion-Lok is McElroy Metal's most popular snap-together panel and has been utilized to add beauty and function on projects all across the country.



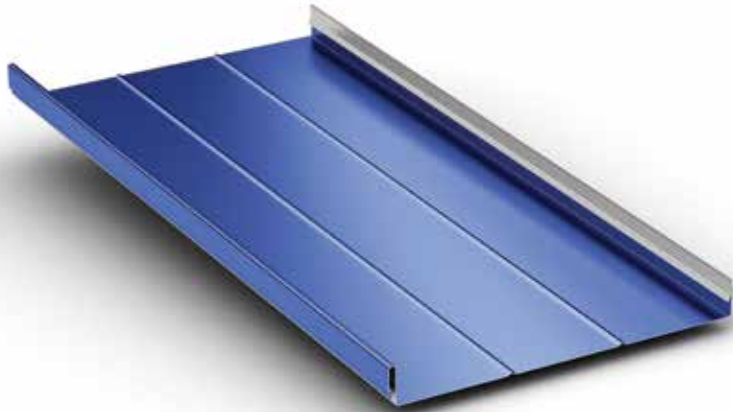

Standard Clip



UL 90 Clip



Seam Detail



Factory Eave Notch



Eave Notch
Folded In Field



Panel Options

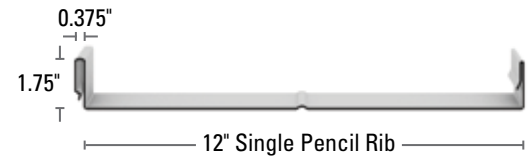
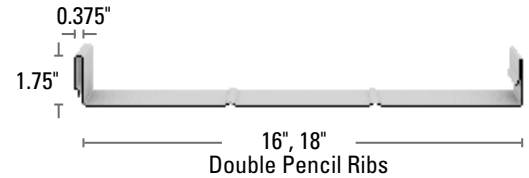
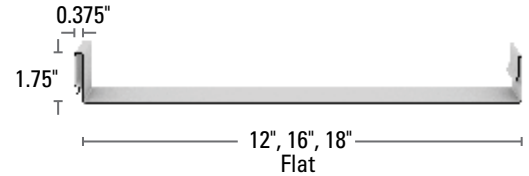
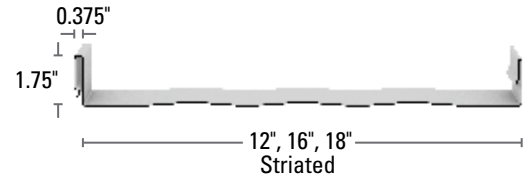

Note: Striated panels are recommended as they reduce the appearance of oil canning

Details

- Factory formed eave notch upon request
- Factory applied sealant
- Minimum slope: 3:12
- Can be installed over solid deck or open framing

Panel Options

- Panel width 12", 16" & 18"
- Panel configurations: striated, ribbed or flat pan (striated recommended)
- Coating: Kynar 500® (PVDF)
- Substrate:
 - Standard 24 gauge Galvalume®
 - Optional 22 gauge Galvalume
 - .032 and .040 aluminum

Testing Data

- Fire Rating: Class A
- Uplift Test: UL580 Class 90 ASTM E1592
- Air Infiltration: ASTM E1680
- Water Infiltration: ASTM E1646
- Class 4 Impact Resistance: UL 2218
- Florida State Approval: 1747.5 and 1832.7
- Fire Resistance: UL 263
- Miami Dade Approval: NOA#13-0430.06
- ICC-ES Approval: ESL-1082
- For any available Test Data, Section Properties or Load Tables, please visit our download section at www.mcelroymetal.com

Oil canning (pan wave) is a natural occurrence in metal panels and is not a cause for panel rejection.



Corporate Office
1500 Hamilton Rd., Bossier City, LA 71111
www.mcelroymetal.com | info@mcelroymetal.com

Medallion-Lok Panel

Product Data

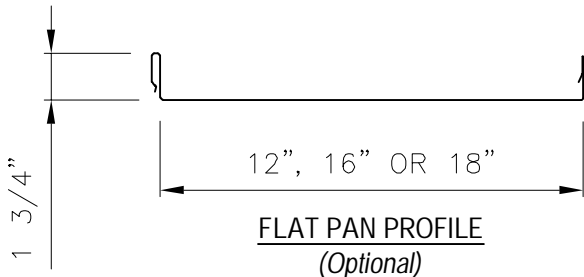
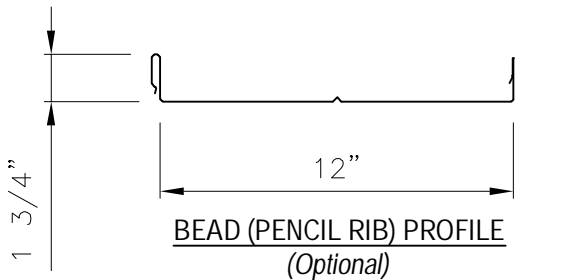
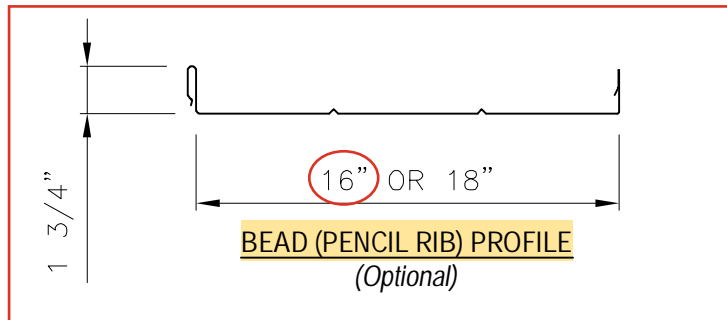
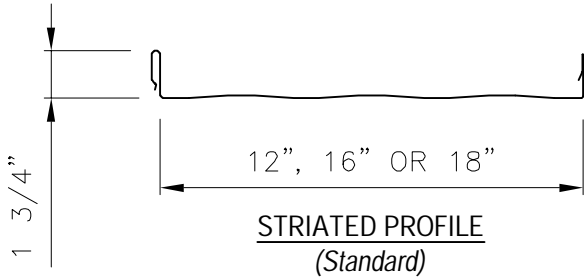

Applications

Snap Seamed roof panel used on slopes down to 3:12. Continuous length up to 75'. Please inquire for longer lengths.

Substrates

Plywood, Metal Deck, Rigid Insulation/Metal Deck or Open Framing.

Material

Standard - 24 GA. ASTM A792 (50 ksi steel) AZ55 - Bare
AZ50 - Painted
Optional - 22 GA. ASTM A792 (50 ksi steel) AZ55 - Bare
AZ50 - Painted
and .032 Aluminum (Sunnyvale Plant Only)

Manufacturing

Roll formed in factory.
Available Factory Eave Notching of 1 1/2"

Finishes

Acrylic Coated Galvalume®
Fluoropolymer (Kynar 500® PVDF resin-based)

Pan Conditions

Flat Pan, Pencil Ribbed or Striated
Oil canning is inherent in all metal panels and is not cause for panel rejection. A signed oil canning acknowledgement will be required for all orders prior to production.

Testing *

Uplift: UL 580 Class 90, ASTM E1592
Air & Water Infiltration: ASTM E1680, and ASTM E1646.
Fire Resistance: UL 263 & UL 790 Class A
Impact Testing: UL 2218 Class 4
Miami Dade Approval: NOA# 18-0327.11
Florida Product Approval: FL 1747.5 & FL 1832.7
Texas Department of Insurance: RC-573
*Testing and Approvals are product specific. Please inquire for details. *

NOTE:

All data represented on this sheet may not be applicable to all widths and gauges. Please contact McElroy Metal for more information.

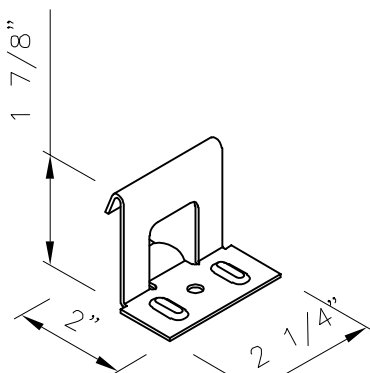

STANDARD CLIP

16 GA. Galvanized G90 - ASTM A653 (50 ksi)

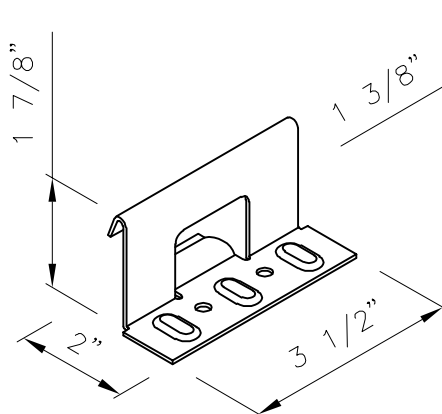

UL-90 CLIP

16 GA. Galvanized G90 - ASTM A653 (50 ksi)

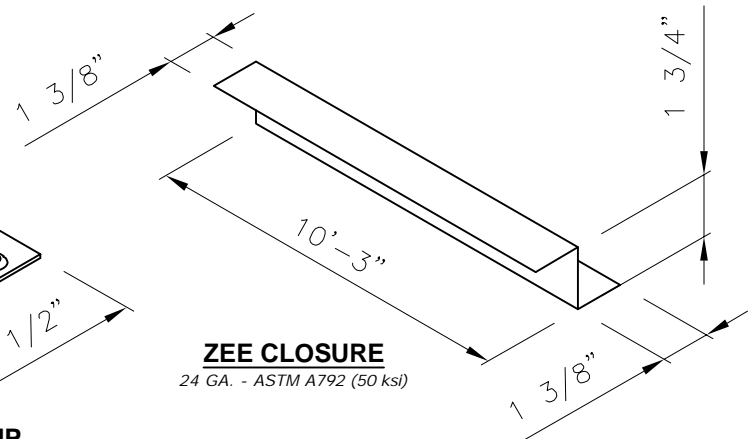

ZEE CLOSURE

24 GA. - ASTM A792 (50 ksi)



TECHNICAL BULLETIN

Issue Date : June 28, 2011

Revised: October 3, 2024

No. 99-326-11

Approved Underlayments

	Product Name	Manufacturer	Date Approved
Nail Down	Triflex 30	WR Grace	2007
	Titanium UDL	Interwrap, Inc.	11/13/2003
	Roofshield UDL	Berger	2/1/2006
	Alpha Protector SUL	AlphaProTech	3/9/2006
	Quantum 30 Hybrid	Elk Corporation	6/28/2006
	Palisade	SDP Inc.	9/27/2006
	PermaFelt	Perma R Products	5/14/2008
	Nova Seal II	Intertape Polymer Group	3/4/2009
	Alco Shield Sythetic Underlayment	Alco	12/10/2012
	Hydrashell 25	Marco Industries	5/30/2015
	Hydrashell 50	Marco Industries	5/30/2015
	Low-E Therma-Sheet	Environmentally Safe Products	3/2/2016
	Hydrashell Max	Marci Industries	12/20/2017
	LastoBond Stick VP**	Soprema	3/6/2018
	Protectite Ultra	Epilay	2/16/2022
RoofingFoil	AtticFoil Radiant Barrier Supply, LLC	6/26/2023	
Peel and stick	CCW WIP 300 HT	Carlisle Coatings and Waterproofings	6/27/2005
	HT Sheildgard	Elk/RGM Products	7/4/2006
	TamkoTW	Tamko	6/16/2007
	Tamko TW Metal & Tile	Tamko	2008
	Lite & Smooth (#964)	Dewitt's	5/14/2009
	High Temp Polyester (#965)	Dewitt's	5/14/2009
	LeakBarrier PS200HT	Tarco	5/14/2009
	Polystick TU Plus	Polyglass	7/28/2009
	Polystick MTS Plus	Polyglass	8/28/2009
	LastoBond Shield HT	Soprema	10/19/2009
	Blueskin Tile & Metal	Henry	6/20/2011
	Blueskin High Temp	Henry	6/20/2011
	Quik-Stick HT Pro	Mid States Asphalt	7/19/2012
	WIP 250	Carlisle Coatings and Waterproofings	9/13/2012
	Palisade-SA-HT	SDP Advanced Polymer Products, Inc.	9/13/2012
	Alco Shield HT	Alco	12/10/2012
	MetaLayment	Certainteed	7/9/2014
	HydraShell HT200	Marco	6/2/2015
	Stormguard	GAF	2/2/2016
	Ultra HT Wind & Water Seal	MFM Building Products Corp.	4/6/2017
	HydraShell Supreme - SA	Marco	5/9/2017
	Epistik Plus	Epilay	5/24/2021
	Polystick XFR	Polyglass	3/3/2022
	PSU 30	Interwrap/Owens Corning	2/27/2024
	Plasfelt	Epilay	10/3/2024

**This is a peel and stick and does not require fasteners for installation.

**CORPORATE OFFICE
SHREVEPORT, LOUISIANA**